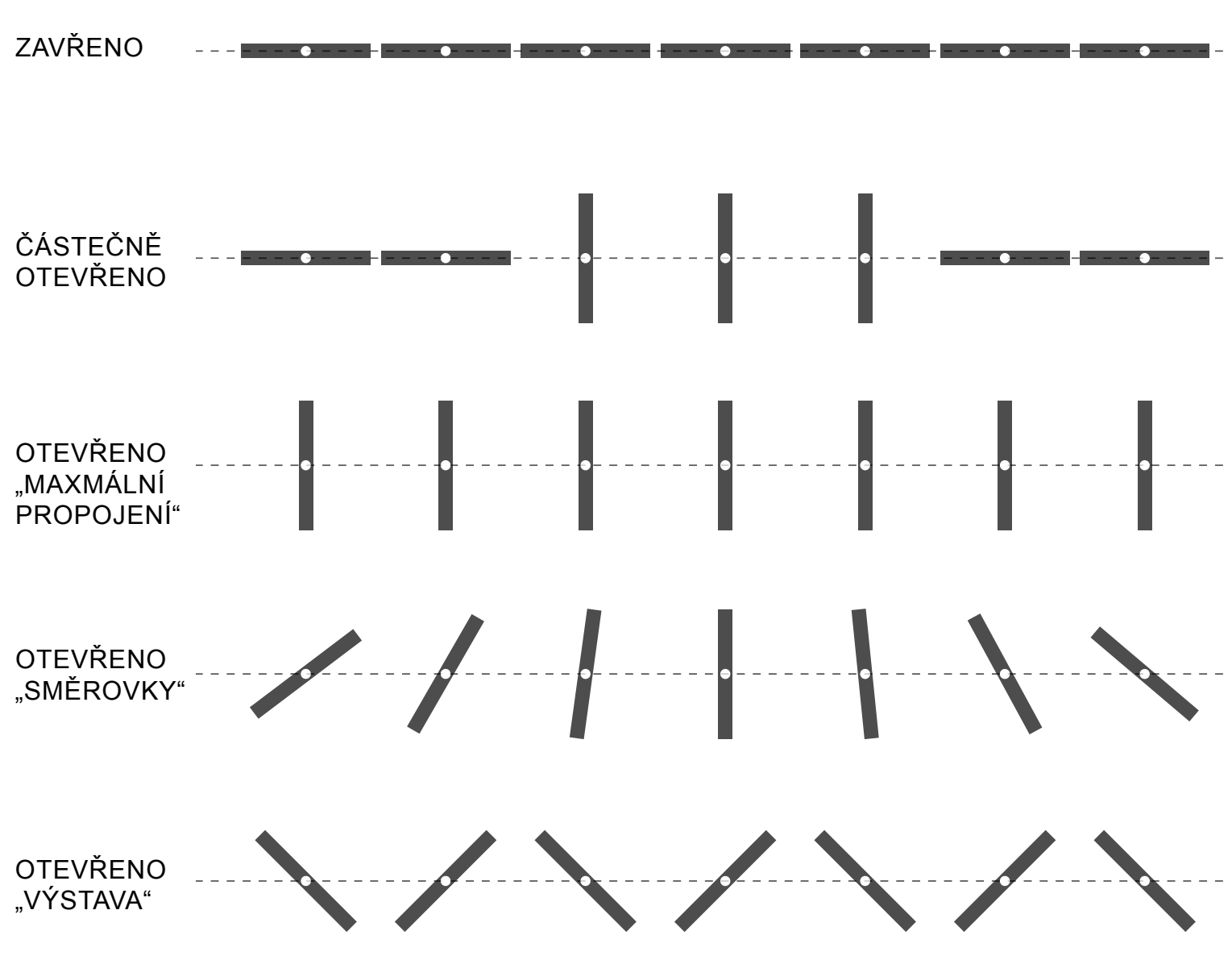
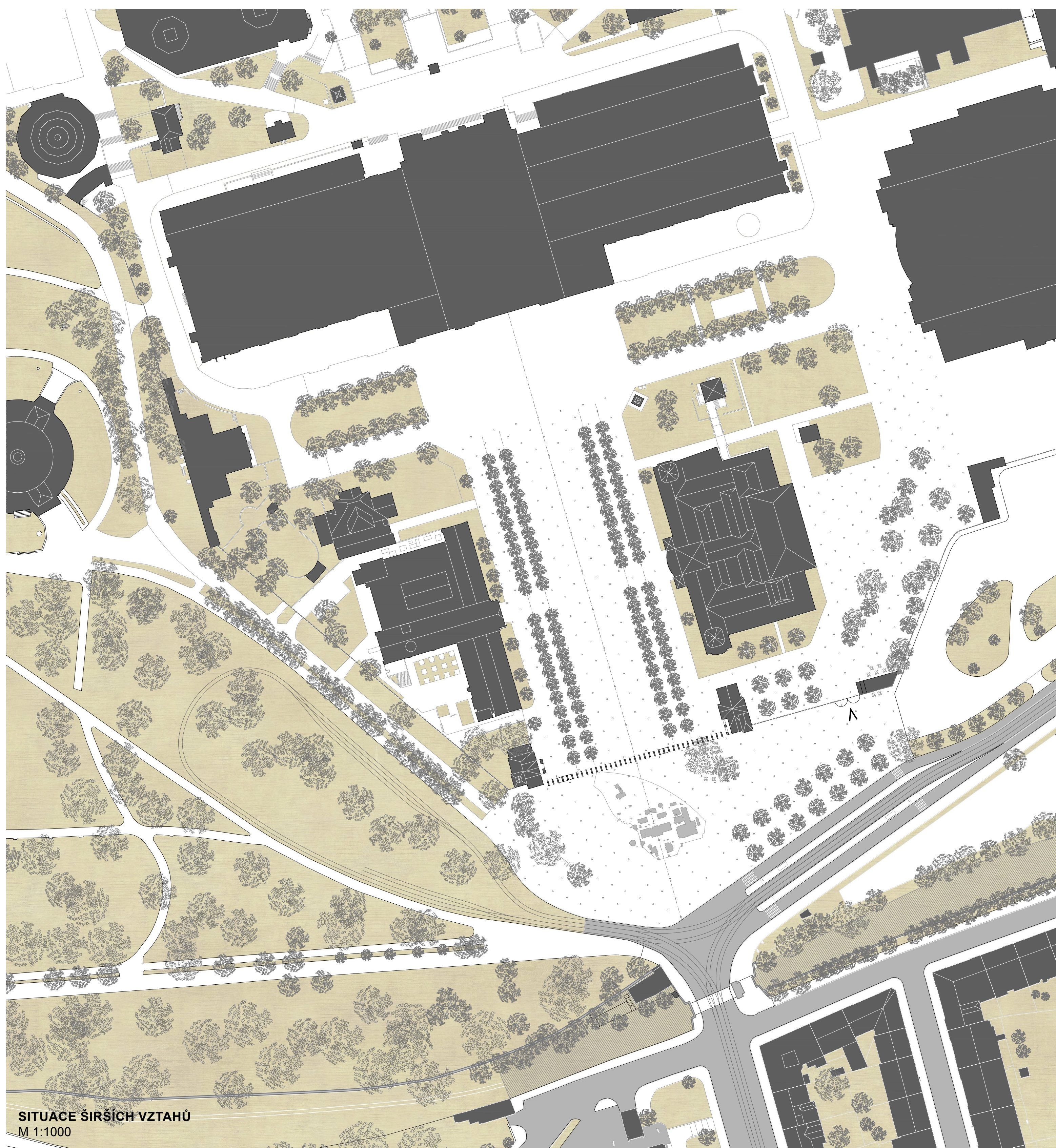

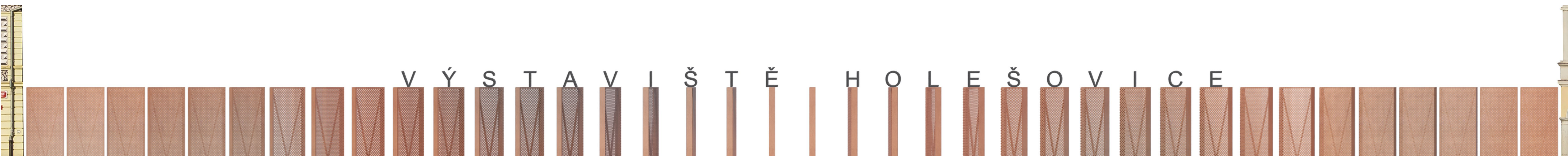
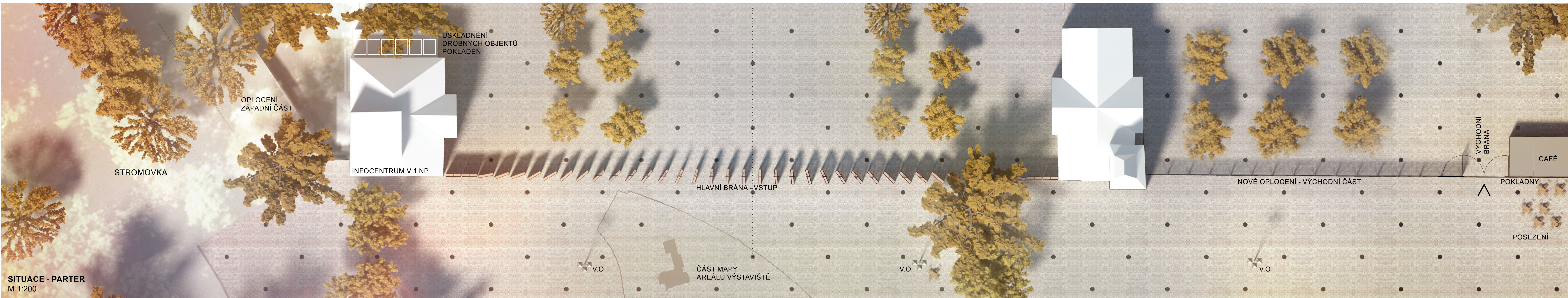

DIAGRAM VARIABILITY BRÁNY
RÚZNÉ PROVOZY



SITUAČNÍ SCHEMA





JIŽNÍ POHLED
VSTUPNÍ LICOVÁ STRANA BRÁNY - OTEVŘENO DO VĚJÍŘE
M 1:100

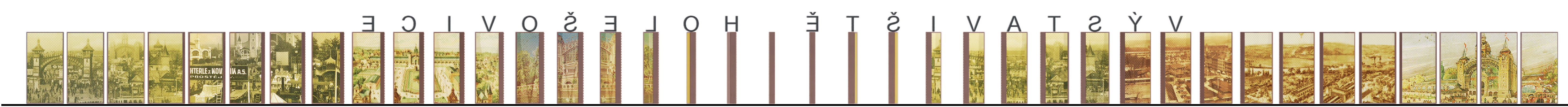

SEVERNÍ POHLED
RUBOVÁ STRANA BRÁNY - OTEVŘENO DO VĚJÍŘE
M 1:100

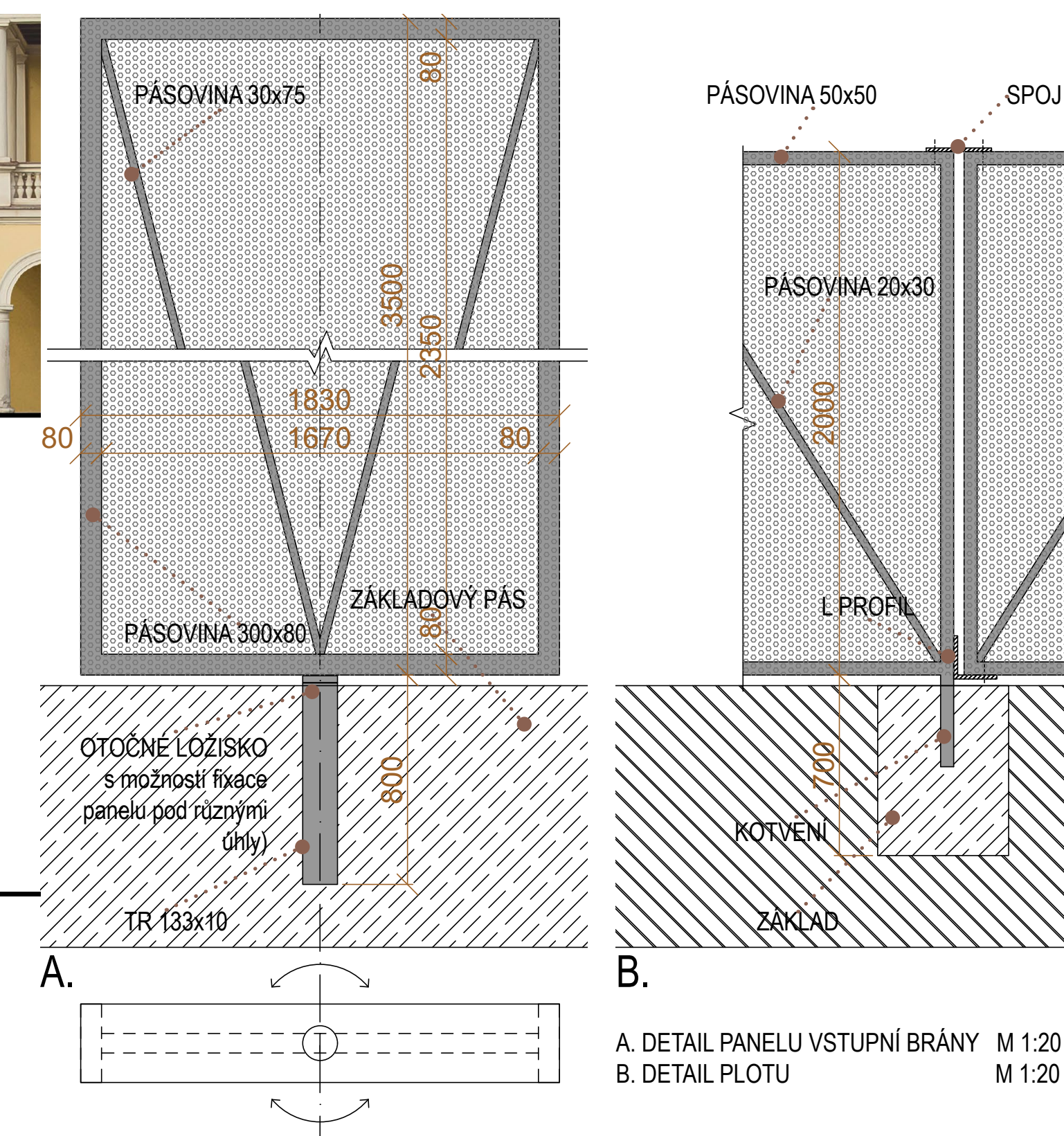

A. DETAIL PANELU VSTUPNÍ BRÁNY M 1:20
B. DETAIL PLOTU M 1:20

AXONOMETRICKÉ SCHÉMA BRÁNY
DLE RŮZNYCH PROVOZŮ

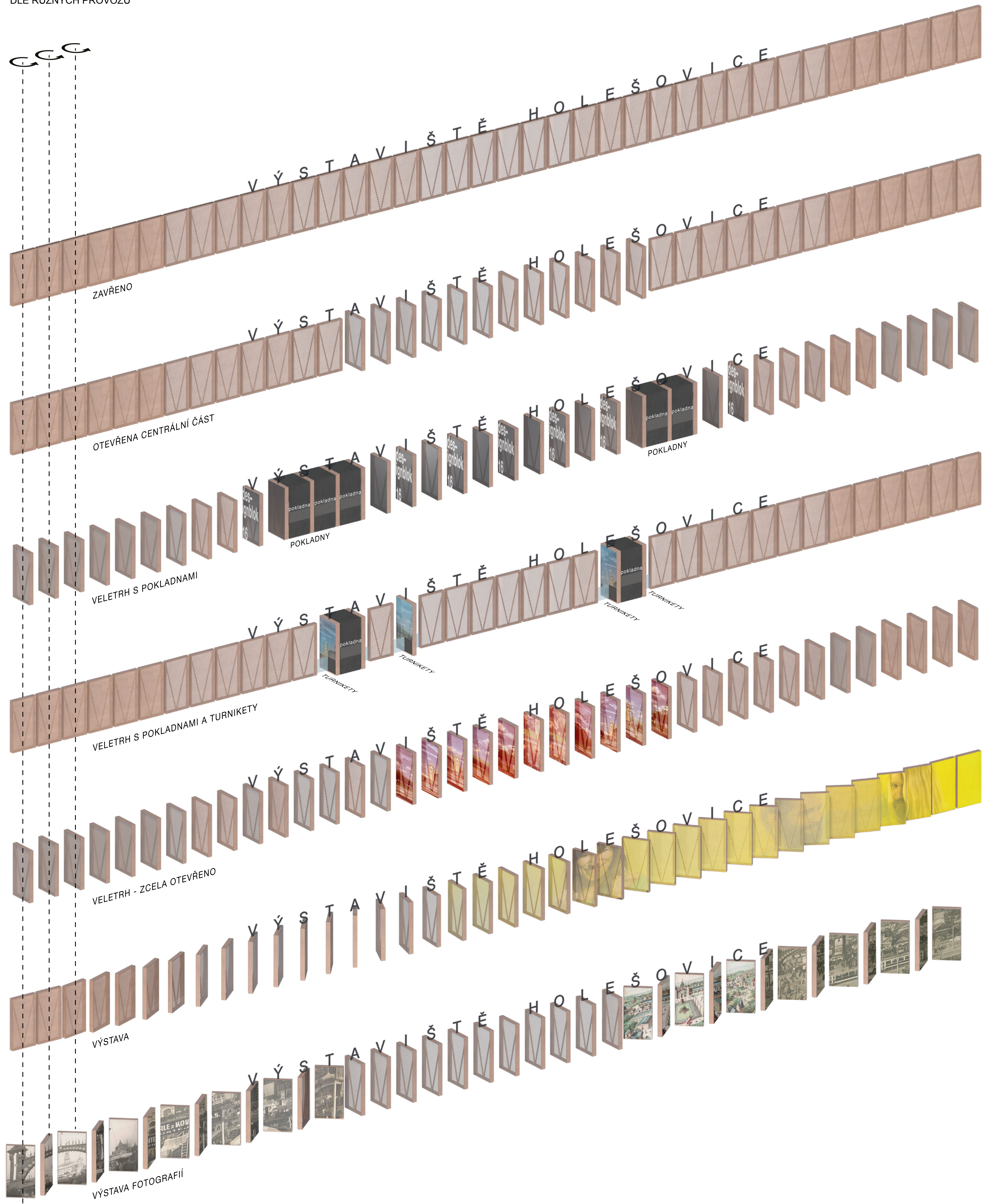

STATICKÉ MODELY
3D PŘEMÍSTĚNÍ

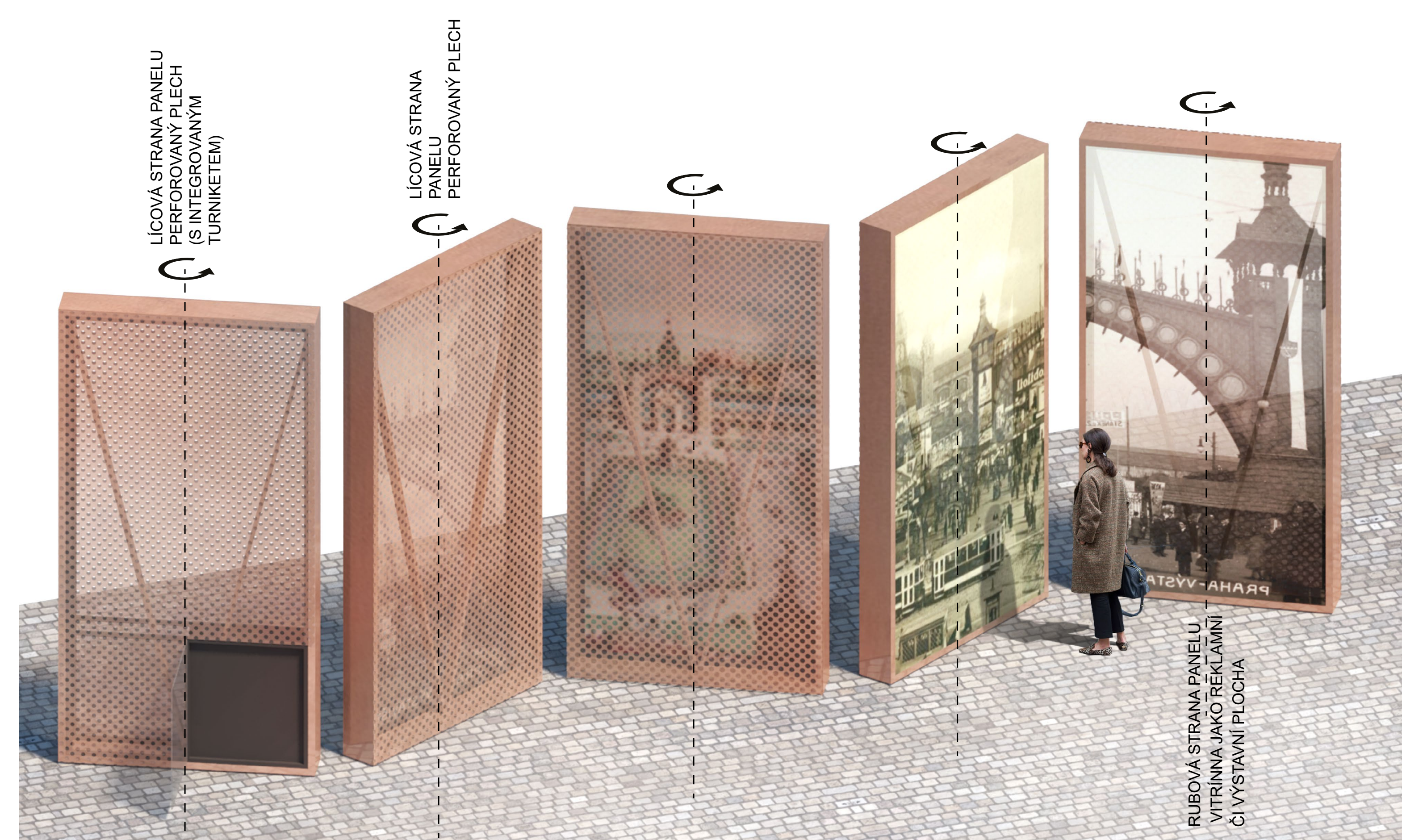
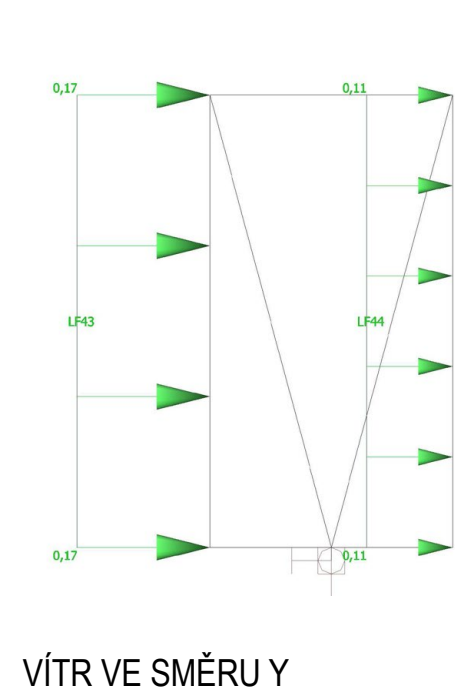
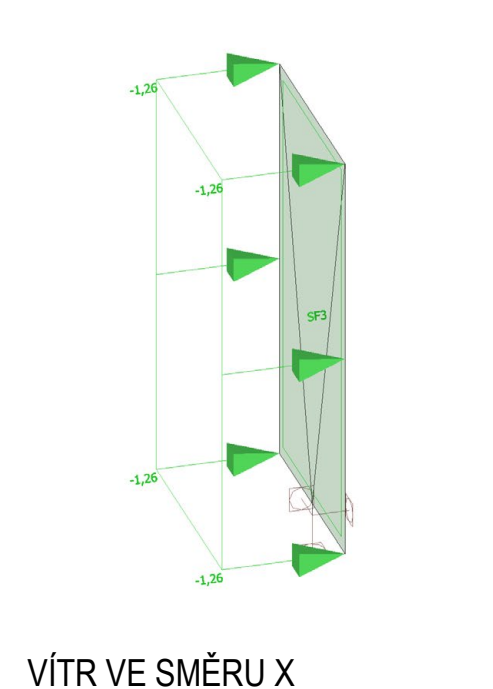
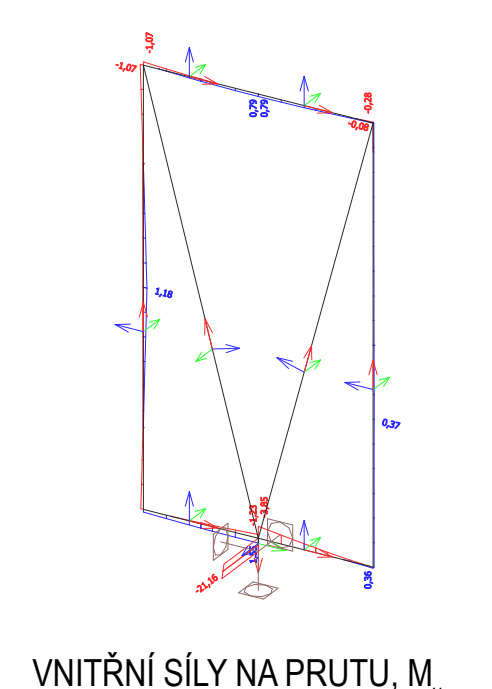
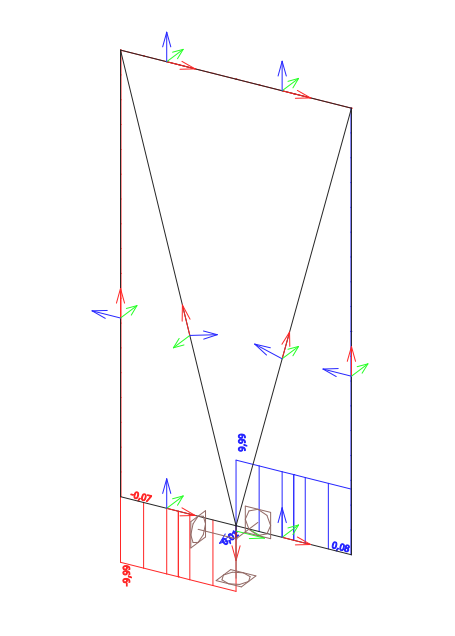
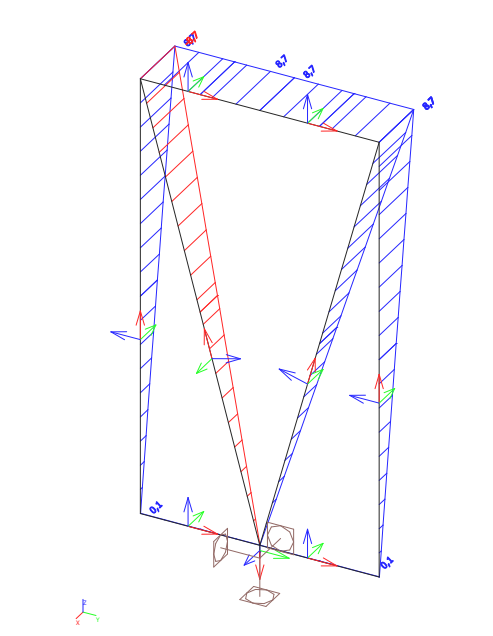
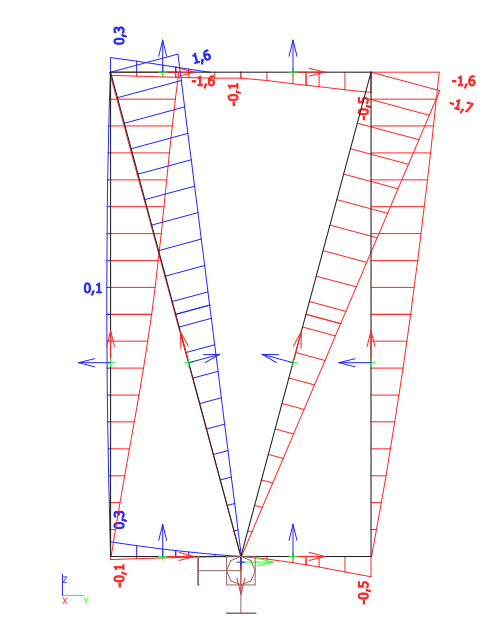
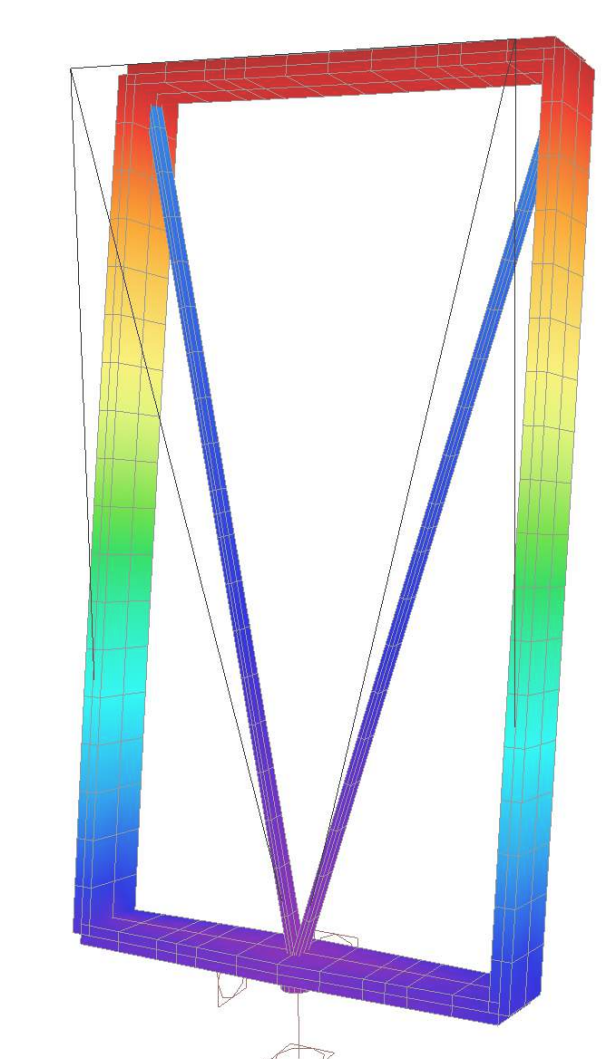
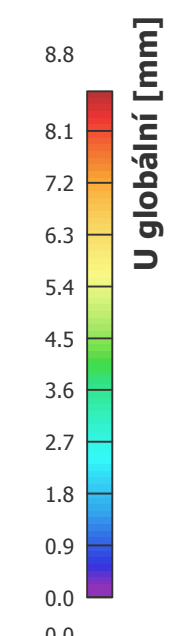

PŘÍKLADY - REFERENCE

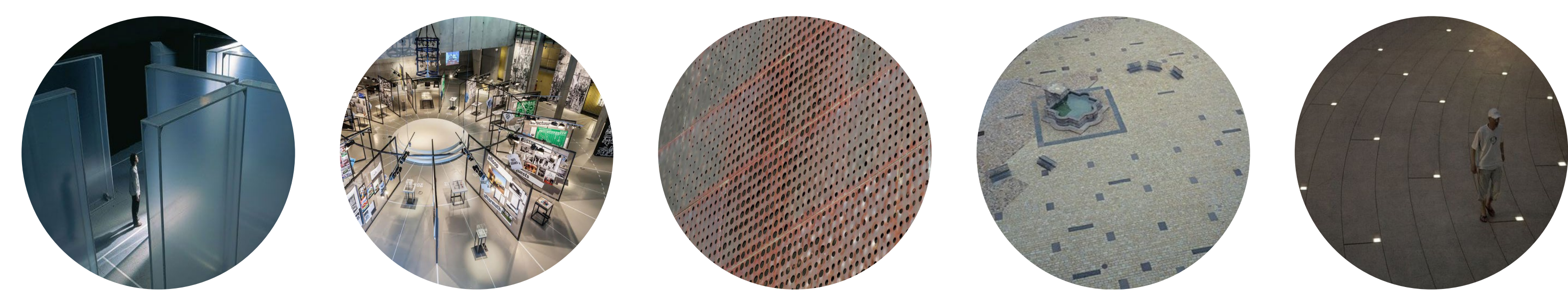

NÁVRH - MATERIÁLY, PRVKY

